

Oceanic Iron Ore Corp.

Management's Discussion and Analysis of Financial Condition and Results of Operations Third Quarter Report – December 31, 2014 and 2013

The following discussion is management's assessment and analysis of the results and financial condition of Oceanic Iron Ore Corp. ("Oceanic" or the "Company"), and should be read in conjunction with the accompanying unaudited condensed interim financial statements and related notes. The Company reports its financial statements in accordance with International Financial Reporting Standards ("IFRS") as issued by the International Accounting Standards Board ("IASB"). All figures are reported in Canadian dollars unless otherwise indicated.

Certain information included in this discussion may constitute forward looking statements. Forward looking statements are based on current expectations and entail various risks and uncertainties. These risks and uncertainties could cause or contribute to actual results that are materially different from those expressed or implied. Please see the section entitled "Forward Looking Statements" of this document for further detail on forward looking statements. The effective date of this report is February 25, 2015.

Description of Business

The Company was incorporated on March 8, 1986 under the British Columbia Business Corporations Act. Its common shares are traded on the TSX Venture Exchange.

The Company is focused on the development of the Ungava Bay iron property (the "Property") in Nunavik, Québec, which the Company acquired in November, 2010. The Property comprises three project areas: Hopes Advance, Morgan Lake and Roberts Lake, which cover over 300 kilometres of iron formation and are located within 20 – 50 km of tidewater. The Company has a 100% interest, subject to a 2% net smelter returns royalty ("NSR") in the Property. The Company is currently focused on continuing its development of the Hopes Advance project through a feasibility study and environmental assessment as well as securing a strategic partner for the Hopes Advance project.

Cost Savings

As at December 31, 2014, the Company's cash and cash equivalents balance was \$1,984,270. In light of challenging capital markets, the Company has taken significant measures to optimize and preserve its cash position. This is evidenced through reduced spending at the project level, as well as management salaries and corporate overheads. Consulting and management fees for the nine month period ended December 31, 2014 were \$389,367 (2013: \$412,500; 2012: \$781,468). Investor relations and corporate development costs for the same nine month period were \$152,390 (2013: \$246,142; 2012: \$441,231). Office and general expenses were \$56,578 (2013: \$110,024; 2012: \$116,084). Mineral property exploration costs for the nine month period ended were \$1,180,720 (2013: \$2,060,984; 2012: \$6,017,701). Further, in December 2014, the Company delisted from the OTCQX in the United States which will result in an estimated annual savings of \$20,000 in transfer agent and regulatory fees on a go forward basis. Management will continue to monitor its expenses in order to continue to optimize its cash.

Hopes Advance Project Update

In November 2012, the Company published an NI 43-101 Pre-Feasibility Study in respect of the Hopes Advance project (the "Pre-Feasibility Study"), outlining a pre-tax net present value of the project of \$5.6 billion (post tax net present value of \$3.2 billion), a proven and probable reserve of approximately 1.36 billion tonnes at 32.2% Fe, and highlighting the extensive metallurgical test work undertaken to date, including the completion of bench scale testing and a pilot plant program (see "Pre-Feasibility Study" below). The Pre-Feasibility Study assumes that production from the Hopes Advance project would commence in 2017, following the delivery of a Feasibility Study and Environmental Impact Assessment in 2013/2014.

Oceanic Iron Ore Corp.

Management's Discussion and Analysis of Financial Condition and Results of Operations Third Quarter Report – December 31, 2014 and 2013

The Company undertook to complete critical path Environmental Impact Assessment work during 2014. All of the terrestrial baseline work is now completed. This completes a significant portion of the project assessment work. The outstanding components include marine baseline data inventories and additional consultations with affected stakeholders.

In addition to continuing to carry out work required in respect of ongoing claims maintenance and minimal time sensitive fieldwork in support of the Environmental Impact Assessment and permitting process, the Company is primarily focusing its resources on securing a strategic partner. A top ten global steel producer has completed extensive due diligence related to the Hopes Advance project and the Company is encouraged with progress to date. While overall interest in the iron ore sector has softened in recent months, this has also had the effect of concentrating the focus of prospective investors toward low cash cost development stage projects like Hopes Advance. Given the time necessary to secure an appropriate arrangement with a strategic partner, this is likely to lead to a minimum 12 - 24 month delay to the Company's original development timeline, which initially assumed the delivery of the Feasibility Study and Environmental Impact Assessment during 2013/2014 for the Hopes Advance project.

In July 2013, the Company received a Letter of Intent ("LOI") originating from the Ministry of Finance and Economy of the Government of Québec expressing its interest in participating in a minority stake investment in Oceanic's Hopes Advance project, subject to additional future approvals of the Government of Québec. The government's financial contribution is expected to originate from the province's Mining and Oil Capital fund (the "Fund") which has been allocated a budget of \$750 million for investment in the non-renewable natural resources sector. The Fund was announced in November 2012 as part of the 2013-2014 budget speech of the Government of Québec. The LOI from the Ministry of Finance and Economy indicates that the terms of the financial contribution will be further defined as the Company reaches agreement with a senior strategic partner for the project.

Renaming of Deposits

In January 2015, the Company renamed several deposits within the Hopes Advance project area in recognition of prominent individuals whose contributions were pivotal in the discovery of the area as well as the future work undertaken in the region. The Castle Mountain deposit has been renamed the Ross Toms Mine, the Zone 4 deposit has been renamed the Sheridan Mine, and the Bay Zone deposits are now known as the Ferderber Mine.

Achievements to Date – Hopes Advance Project

Active development of the Hopes Advance project commenced in March 2011 with the start of the Company's resource verification program.

Since then, milestones have been achieved in a number of areas:

1. Project Technical Study and Economics

- In November 2012, the Company published its Pre-Feasibility Study which reports an estimated pre-tax NPV of \$5.6 billion (post-tax NPV of \$3.2 billion), and pre-tax IRR of 20.5% (post-tax IRR of 16.8%) over a 31 year projected mine life at an 8% discount rate (see "Pre-Feasibility Study" below).

2. Resource definition

- In November 2012, as part of its Pre-Feasibility Study, the Company published an updated NI 43-101 compliant In-Pit Mineral Resource Estimate for the Hopes Advance project of 774,241,000 tonnes at 32.2% Fe measured, 613,796,000 tonnes at 32.0% Fe indicated

Oceanic Iron Ore Corp.

Management's Discussion and Analysis of Financial Condition and Results of Operations Third Quarter Report – December 31, 2014 and 2013

and 222,188,000 tonnes at 32.5% Fe inferred. Inferred resources are not included in the Pre-Feasibility mine plan or project economics (see "Resource Estimate – Hopes Advance Project" below).

3. *Economic Mineral Reserves*

- In November 2012, as part of its Pre-Feasibility Study, the Company published an NI 43-101 compliant mineral reserve estimate of 763,276,000 tonnes at 32.3% Fe proven and 595,990,000 tonnes at 32.1% Fe probable for a total proven and probable reserve of 1,359,266,000 tonnes at 32.2% Fe (see "Resource Estimate – Hopes Advance Project" below).

4. *Metallurgy*

- Metallurgical bench scale testing program conducted by SGS Mineral Services Lakefield ("SGS") over approximately 600 composite samples from various deposits at the Hopes Advance project which demonstrated high weight recoveries with a high percentage of iron recovery from the gravity process, as well as low levels of deleterious materials.
- Completion of a pilot plant testwork program also conducted by SGS to determine a flowsheet for the recovery of hematite and magnetite. The pilot plant testwork was also used to determine the appropriate size of equipment for the flowsheet as well as optimal grinding equipment and power requirements (see "Metallurgical Pilot Plant Program" below).

5. *Product Versatility and Marketability*

- Completed a Process and Product Optimization Study, led by Met-Chem with the associated laboratory test work completed by SGS, which illustrates the flexibility and marketability of the Hopes Advance project across a range of potential strategic partners and off-take customers. The Product Optimization Study concluded that the Hopes Advance project is capable of producing 2.4 million tonnes per annum of its initial 10 million tonnes per annum output (4.8 million tonnes per annum post expansion) of a fine fraction sinter quality product, at a 5.5% silica target (see "Product Optimization Study" below). The Company will decide during the feasibility stage of the project whether a two product circuit is worth pursuing.
- Completion of a Product Value-In-Use Marketing Study, led by Vulcantech Technologies Pty Ltd., which concluded that in addition to the iron unit premium for the high grade Hopes Advance product at 66.6% Fe measured against the 62% Fe benchmark, an estimated minimum 10% value-in-use premium can be anticipated due to the product's high quality and low impurities (see "Marketing Study" below).
- Completed a Pot Grate test work program, performed by Coleraine Minerals Research Laboratory and supervised by Rod Johnson, VP Geometallurgy, which concluded that with the addition of limestone and dolomite, concentrates from the Company's Hopes Advance project are capable of being transformed into high quality pellets, with very low deleterious elements and compressive strengths of up to 638 lbs and swelling of 10.6% (see "Pot Grate Test Work Program" below).
- Completion of a Shipping Optimization Study, led by AMEC Environment and Infrastructure that concludes with greater certainty that the Company's shipping strategy, which will include direct shipments during ice free months from Breakwater Point and transshipment during winter months, is technically feasible and supports the cost projections contained in

Oceanic Iron Ore Corp.

Management's Discussion and Analysis of Financial Condition and Results of Operations Third Quarter Report – December 31, 2014 and 2013

the Company's Preliminary Marine Facility and Shipping Logistics Study announced September 22, 2011 (see "Shipping Optimization Study" below).

6. *Infrastructure*

- Defined a project implementation and development schedule independent of third party infrastructure with construction and operations to commence with self-generated power and self-constructed port and marine infrastructure.
- Completion of a marine logistics study in September 2011 by AMEC Environment and Infrastructure acknowledging the viability of constructing a deep water port facility at Hopes Advance and that year-round shipping using Cape Size vessels is feasible.
- Construction of a camp facility near the village of Aupaluk as a base for crews supporting the completion of the Pre-Feasibility Study, as well as future fieldwork.

7. *Community/Government Relations and Support*

- Establishment of positive relations with the Inuit community including signing of a letter of intent setting the terms and conditions on which the Company plans to develop the Hopes Advance project.
- Receipt of a LOI in July 2013 from the Ministry of Finance and Economy of the Government of Québec with respect to its interest in participating in a minority stake investment in Oceanic's Hopes Advance project, subject to additional future approvals of the Government of Québec.

8. *Environmental (see "Environmental Review" below)*

- Acceptance of the Project Description by the Canadian Environmental Assessment Agency under new regulations in accordance with the Canadian Environmental Assessment Act 2012.
- Receipt of Project Guidelines from the Canadian Environmental Assessment Agency.
- Receipt of Project Guidelines from Kativik Environmental Quality Commission through the Québec Ministry of Sustainable Development, Environment and Parks, Administration of Environmental Assessment for Northern Mining Projects 'Ministère du Développement durable, de l'Environnement et des Parcs Direction de l'évaluation environnementale des projets nordiques et miniers', which advances the Hopes Advance project to the next stage of the overall assessment process provincially.
- Acceptance of a ruling provided by the Hon. Peter Kent, Minister of Environment, regarding the marine portion of the Hopes Advance project to the Nunavik Marine Region Impact Review Board ("NMRIRB") for a Part 5 Review in association with the Canadian Environmental Assessment Act 2012 ("CEAA 2012") and the Nunavik Inuit Land Claims Agreement, whereby the review process of the Company's Environmental Impact statement will be streamlined such that only one submission will be needed and will respond to both CEAA 2012 as well as the NMRIRB requirements under the Nunavik Inuit Land Claims Agreement.
- Receipt of environmental guidelines from the NMRIRB
- Completion of terrestrial baseline work in 2014
- Preparation of protocols for marine baseline studies during 2014

Oceanic Iron Ore Corp.

Management's Discussion and Analysis of Financial Condition and Results of Operations
Third Quarter Report – December 31, 2014 and 2013

- Ongoing fieldwork to support Environmental Impact Assessment and permitting process

Pre-Feasibility Study

The base case in the Pre-Feasibility Study assumes initial production of 10 million tonnes of concentrate per annum commencing in 2017 utilizing self-generated power, expanding to production of 20 million tonnes of concentrate per annum using hydroelectric power from 2027, following connection to the grid in 2025 and construction to support the expansion in 2025 and 2026. As noted above, there is likely to be a minimum 12 - 24 month delay to the commencement of production.

The Pre-Feasibility Study has been based on the Mineral Resource prepared by Eddy Canova, P.Geo., O.G.Q reported in a Company news release on April 2, 2012 and filed on SEDAR on May 17, 2012.

Pre-Feasibility Metrics

Table 1 below lists the key Pre-Feasibility Study estimated metrics.

Table 1 – Pre-Feasibility Study Results

Variable	Results	
Price assumption – FOB	\$100 / tonne	
Net Present Value (8%) (pre-tax/post-tax)	\$5.6 billion	\$3.2 billion
Pre-tax IRR (unlevered / levered)	20.5%	23.2%
Post-tax IRR (unlevered / levered)	16.8%	19.2%
Post-tax Payback	5 years	
Mine Life	31 years	
10 Million Tonne Initial Capital Costs	\$2.85 billion	
20 Million Tonne Expansion Capital Costs	\$1.61 billion	
Sustaining Capital Expenditure (LOM)	\$0.77 billion	
Life of Mine Operating Cost per tonne	\$30.18/tonne	
Strip Ratio Years 1 – 15	0.57	
Strip Ratio Life of Mine	1.17	

As noted above, the Pre-Feasibility Study assumes a concentrate selling price of \$100/tonne FOB and also takes into consideration the 2% royalty payable to the vendors of the project. The Pre-Feasibility Study assumes that the Company exercises its right to purchase half of this royalty for \$3 million in the first year of commercial production. The Study assumed a USD:CAD of 1:1. Recent and expected trends in the Canadian dollar exchange rate relative to the US dollar have a positive impact on the project economics, partially offsetting the effect of recent decreases in the price of iron ore. These variables will be updated when the Company completes its Feasibility Study. Analysis of the economics has been undertaken on

Oceanic Iron Ore Corp.

Management's Discussion and Analysis of Financial Condition and Results of Operations Third Quarter Report – December 31, 2014 and 2013

both a pre-tax and post-tax basis and IRR is presented on both an unlevered and levered basis. In respect of the leveraged case, the key assumptions are as follows:

- Initial capital 60% debt financed;
- Annual interest rate of 8%;
- Upfront financing fee of 3%;
- 7 year term post commencement of commercial production;

Expansion capital is assumed funded through operating cashflow.

Operating Costs

A summary of the estimated operating costs is set out in Table 2 below:

Table 2 – Operating Costs (excluding royalty)

Category	Years 1 - 8	Years 9 - 10	Years 11 – 31	Life of Mine Average
	(10 MM T/YR & Self-Generated Power)	(10 MM T/Y & Hydroelectric Power)	(Post Expansion - 20 MM T/YR)	
Mining (\$/tonne all material)	\$1.57	\$1.59	\$1.23	\$1.27
Mining (\$/tonne product)	\$5.46	\$6.30	\$7.78	\$7.37
Concentrator (\$/tonne product)	\$20.87	\$18.35	\$17.45	\$18.02
Port (\$/tonne product)	\$2.13	\$2.13	\$1.45	\$1.58
Site Services (\$/tonne product)	\$3.33	\$2.77	\$2.04	\$2.27
G&A (Site only) (\$/tonne product)	\$1.38	\$1.38	\$0.85	\$0.95
Total Operating Cost / tonne product (excluding royalty)	\$33.17	\$30.93	\$29.57	\$30.18

The low operating costs are a function of a number of factors including:

- No rail component given the project's proximity to the identified port site at Pointe Breakwater;
- A very low strip ratio, averaging 0.57:1 waste to ore in the first 15 years of production and 1.17:1 over the life of mine;

Straightforward metallurgy and high Fe recoveries, reflected in the simple flowsheet and low operating costs.

Oceanic Iron Ore Corp.

Management's Discussion and Analysis of Financial Condition and Results of Operations
Third Quarter Report – December 31, 2014 and 2013

Metallurgical Pilot Plant Program

Background

During 2012, the Company completed a comprehensive metallurgical bench scale testing program, in addition to a pilot plant testwork program led by SGS. The pilot plant program was used to determine a flow sheet for the recovery of hematite and magnetite as well as to determine the appropriate size of equipment for the flow sheet and optimum grinding equipment and power requirements.

Bulk Samples and Composites

During the 2011 field season, the Company collected bulk samples to support the bench scale test work and the pilot plant.

The 180 tonne Ross Toms Mine (formerly Castle Mountain) bulk sample was collected from the same three trenches that provided samples for historic metallurgical work conducted in the late 1950's. A 95 tonne sample was composited and blended from the Ross Toms Mine bulk sample for the pilot plant test.

Bench Scale Testing

Bench scale work was conducted on a sample of the Ross Toms Mine bulk sample and included head mineralogy, bench-scale grindability testing, bench-scale gravity and low intensity magnetic separation (LIMS) testing. A full suite of grindability testing was conducted on the sample. The sample was classified as soft to very soft in terms of rod and ball milling (RWI and BWI) and very soft in terms of autogenous milling (AWI). This bench work complements the Mozley Table and Davis Tube test work conducted on drill core composites earlier this year at SGS.

Pilot Plant Testing

The initial flowsheet for the pilot plant test was designed based on historic metallurgical work with modifications indicated by the results of bench scale Mozley Table and Davis Tube tests conducted on drill core composites from Hopes Advance earlier this year (noted above).

The pilot plant test work concluded that an optimized flowsheet composed of single-stage semi autogeneous milling (SAG), followed by rougher, cleaner, and recleaner spirals was optimal. The rougher spiral tails were sent to a LIMS Cobber for recovery of the remaining magnetite. The Cobber concentrate (12.9% of the feed) is then sent to a regrind mill for further liberation of the magnetite. The liberated magnetite is then sent to the two-stage cleaning LIMS to produce an iron rich magnetite concentrate of 70.0% Fe.

The Ross Toms Mine composite, with a Head Fe of 34.2% and a magnetite content of 11.8% (Table 3) responded well to the optimized pilot plant flowsheet. With a target grind of 300 microns the gravity circuit produced concentrate with a SiO₂ content of 4.8%. Not only did the gravity circuit recover hematite, it recovered 46.7% of the magnetite (Table 4). The LIMS circuit with a target grind of 37 microns (minus 400 mesh) produced concentrate with a SiO₂ content of 3.0%. The LIMS circuit recovered another 49.8% of the magnetite. The optimized circuit produced a combined concentrate with 4.5% SiO₂ with a weight recovery of 37.6% and an iron recovery of 73.1%.

Oceanic Iron Ore Corp.

Management's Discussion and Analysis of Financial Condition and Results of Operations
 Third Quarter Report – December 31, 2014 and 2013

Figure 1 – Optimized Flowsheet

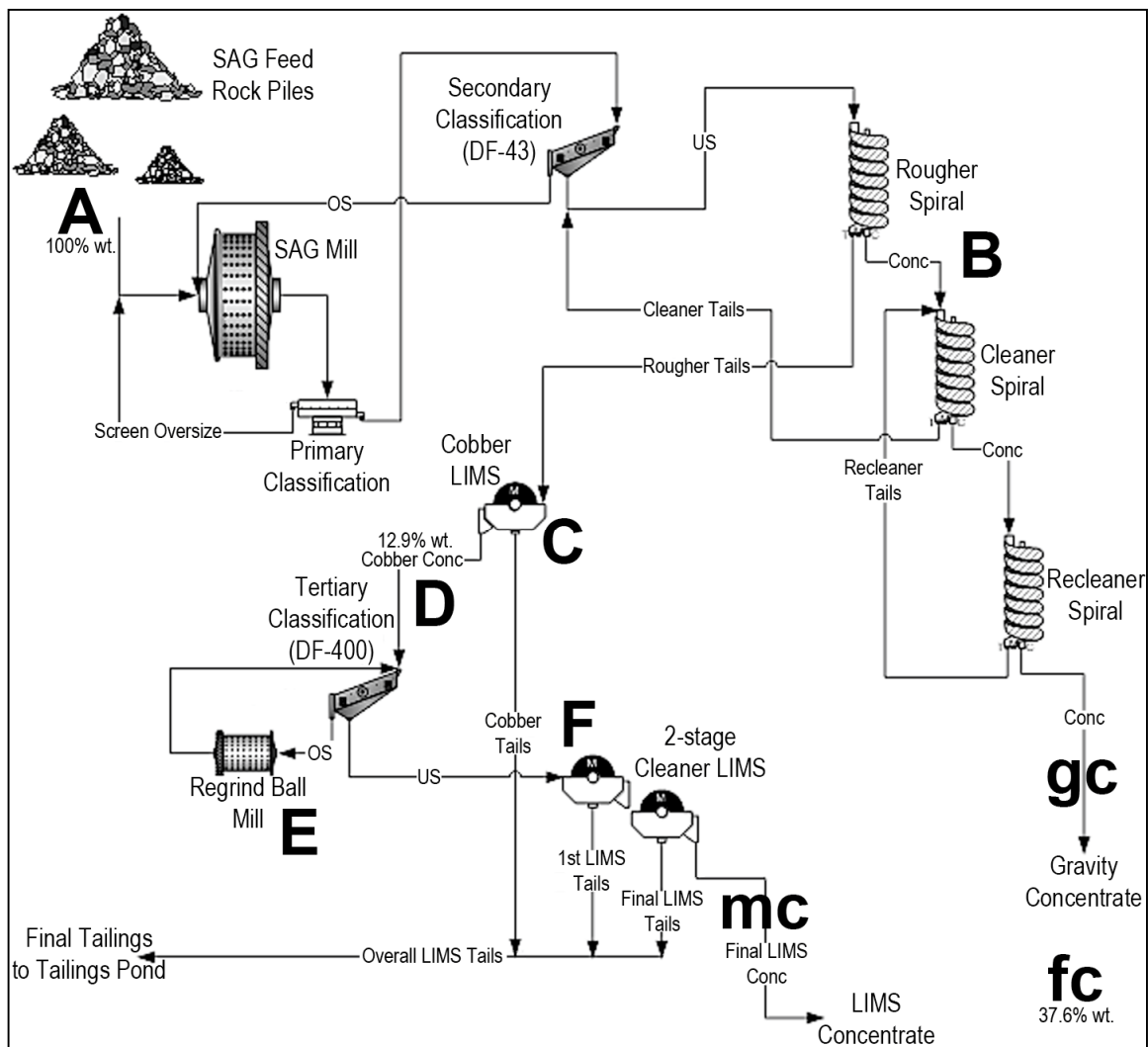

Figure 1 above sets out the optimized flowsheet. A description of the process is set out below:

- A. Crushed ore is fed into a SAG mill (no ball mill required at this stage), where the ore is ground to minus 50 mesh (300 microns);
- B. Ground ore is passed through a series of spirals to recover hematite, coarse magnetite, and aggregates of hematite and magnetite. A gravity concentrate (gc) is recovered;
- C. Tailings (rougher tails) from the spirals are sent to a magnetic cobber (low intensity magnetic cobber) where particles containing magnetite are separated from particles that do not contain magnetite;
- D. Only 12.9% by weight of ore requires fine grinding for magnetic separation processing;
- E. Residual magnetite containing particles are ground to minus 400 mesh (37 microns);
- F. Ground magnetic material is passed through LIMS to recover the remaining magnetite. The magnetite concentrate (mc) is combined with the gravity concentrate (gc) to form the final

Oceanic Iron Ore Corp.

Management's Discussion and Analysis of Financial Condition and Results of Operations
Third Quarter Report – December 31, 2014 and 2013

concentrate (fc). By recovering the magnetite after gravity separation the amount of material that has to be finely ground is significantly reduced.

Table 3 - Analysis of Head for Optimized Ross Toms Mine (formerly Castle Mountain) Pilot Plant Test

Composite	Fe%	Satmagan%
Ross Toms Mine	34.2	11.8

Table 4 - Optimized Pilot Plant product quality and recovery

Composite / Streams	Mass Dist. %	K80 μm	Grade %		Distribution (%)	
			Fe	SiO ₂	Fe	Satmagan
<u>Ross Toms Mine</u>						
Recleaner Spiral Concentrate	31.5	144	65.9	4.8	60.6	46.7
Secondary LIMS Cleaner Con.	6.1	33	70.0	3.0	12.5	49.8
Combined Concentrate	37.6		66.6	4.5	73.1	96.5

The results of the pilot plant test work on the composite suggest that Ross Toms Mine iron ore:

- Is soft;
- Can be processed with a simple flow sheet;
- Produces a concentrate with low SiO₂ and low deleterious elements;
- Produces concentrate with approximately 37.6% weight recovery and approximately 73.1% iron recovery, with 96.5% magnetite content recovery (Satmagan) (see Table 4 above).

The other zones at Hopes Advance can be expected to respond well to a similar flowsheet given the similarity in response to bench scale testing by Mozley Table and Davis tube as indicated by the results shown in Table 5 below.

Table 5 - Summary of overall concentrate grade from Mozley Table and Davis Tube bench tests

Deposit	Overall Concentrate Grade					Overall Recovery			
	Fe %	SiO ₂ %	Al ₂ O ₃ %	Sat %	MnO %	Wt %	Fe %	SiO ₂ %	Sat %
Ross Toms Mine	65.87	4.42	0.02	30.84	0.33	39.34	78.60	4.34	73.97
Iron Valley	65.97	4.64	0.04	25.48	0.33	40.49	80.58	4.76	62.92
Ferderber Mine	66.96	4.46	0.03	59.15	0.28	40.08	81.01	4.38	81.06
West Zone	66.20	4.31	0.03	42.55	0.58	40.19	76.93	4.49	73.11

Oceanic Iron Ore Corp.

Management's Discussion and Analysis of Financial Condition and Results of Operations
Third Quarter Report – December 31, 2014 and 2013

Resource Estimate – Hopes Advance Project

In November 2012, the Company published an updated NI 43-101 compliant In-Pit Mineral Resource Estimate for the Hopes Advance project of 774,241,000 tonnes at 32.2% Fe measured, 613,796,000 tonnes at 32.0% Fe indicated and 222,188,000 tonnes at 32.5% Fe inferred. In addition, mineral reserves have been estimated at 763,276,000 tonnes at 32.3% Fe proven and 595,990,000 tonnes at 32.1% Fe probable for a total proven and probable reserve of 1,359,266,000 tonnes at 32.2% Fe.

Mineral reserves for the Hopes Advance project have been estimated as summarized in Table 6 below. Mineral reserves have not been estimated for the Ferderber Mine B (formerly Bay Zone) or West Zone 2 pits as they are classified as inferred resources.

The open pit reserves, summarized below, are based on a 25% Fe cut-off grade. The reserves shown below are calculated based on industry standard pit optimization techniques guiding detailed pit designs including ramps and surface constraints. The mineral reserve is contained within the mineral resource. The effective date of the mineral reserve estimate is September 19, 2012.

Table 6 – NI 43-101 In-Pit Mineral Reserve Estimate Hopes Advance Bay (25% Fe Cut-off)

Category	Tonnes	Fe (%)	Wt. Recov. (%)	Concentrate Tonnes
Proven Reserves	763,276,000	32.3%	37.4%	285,428,000
Probable Reserves	595,990,000	32.1%	37.1%	221,246,000
Proven & Probable Reserves	1,359,266,000	32.2%	37.3%	506,675,000

The ultimate pit limits are based on the economic Lerchs-Grossmann algorithm designed to honour the property boundary and the setback from the lakes. The mine plan developed in this Pre-Feasibility Study is based on Measured and Indicated resources only. Inferred resources are not included in the Pre-Feasibility Study mine plan or project economics. There is opportunity to upgrade some minor amounts of the inferred resource mineralization to ore classification with additional infill drilling.

The Pre-Feasibility Study mine schedule and economic analysis does not include inferred resources of approximately 72.7 million tonnes of 32.8% Fe. Mineral resources that are not mineral reserves do not have demonstrated economic viability.

The mineral resource estimates are classified as “measured”, “indicated”, or “inferred” as defined by the Canadian Institute of Mining (“CIM”). According to the CIM definitions, a Mineral Resource must be potentially economic in that it must be “in such form and quantity and of such grade or quality that it has reasonable prospects for economic extraction”. For the Hopes Advance iron deposit, an iron cut-off grade was assigned based on economic assumptions and metallurgical parameters and was used in the resource estimations.

The “April, 2012” mineral resource estimate is effective as of 2 April 2012 and was prepared by Micon International Limited (“Micon”) under the direction of Eddy Canova, the Company’s Director of Exploration and a Qualified Person as defined in NI 43-101.

The “September, 2012” mineral resource estimate is effective as of 19 September 2012 and was prepared by Micon International Limited (“Micon”) under the direction of Eddy Canova. B. Terrence Hennessey, P. Geo., has reviewed this work and is the QP for this resource estimate update.

Oceanic Iron Ore Corp.

Management's Discussion and Analysis of Financial Condition and Results of Operations Third Quarter Report – December 31, 2014 and 2013

Further information in respect of the Company's Resource Estimate and Pre-Feasibility Study is available in the full NI 43-101 technical reports available for access on the Company's website (www.oceanicironore.com) and on SEDAR (www.sedar.com).

Environmental Review

The Company appointed Québec based WSP Canada Inc. (formerly GENIVAR Inc.) to lead the completion of the Environmental Impact Assessment in respect of the Hopes Advance project.

As at the date of this report, the Company has received guidelines for the review of the Hopes Advance project from the Canadian Environmental Assessment Agency, the Kativik Environmental Quality Commission and most recently, from the NMRIRB in August 2013. It should be noted that the additional work requirements contained in the new guidelines received from the NMRIRB will not materially impact the overall cost or the overall timetable for completion of the Environmental Impact Assessment.

All guidelines from all agencies are now in place and the Company continues to progress environmental baseline work to support the completion of the Environmental Impact Assessment.

Notwithstanding the Company's decision to defer the majority of the environmental baseline work in 2013, certain aspects of the work have been advanced in order to minimize the impact on the overall future project schedule. These include the completion of hydrological baseline studies during 2013 as well as the preparation of protocols for future baseline activities, all at minimal cost.

In addition, during the current season, the Company completed all of the terrestrial baseline work. WSP Canada Inc. scientists and environmentalists have completed all of the data collection work associated with the land based parameters associated with the project, including compiling inventories of flora and fauna, fish, birds, etc. in the area impacted by the project. This completes a significant portion of the project assessment work. The outstanding components include marine baseline data inventories and additional consultations with affected stakeholders.

Product Optimization Study

In June 2013, the Company completed a process and product optimization study, led by Met-Chem, which enables the Company to determine the potential range of sinter feed and pellet feed product quantities and qualities that can be produced from the Hopes Advance project.

The Product Optimization Study was undertaken to further enhance the Company's understanding of the full range of process and product capabilities for the Hopes Advance project, helping to ensure a broad base for future off-take product agreements, including the maximization of potential premiums and the optimization of the Company's targeting of potential future end user markets and potential development partners.

The Product Optimization Study illustrates the flexibility and marketability of the Hopes Advance project across a range of potential strategic partners and potential off-take customers. In particular, the Product Optimization Study concludes that with minor alterations to the grinding process, as well as some minor changes to the downstream material handling system, the Hopes Advance project is capable of producing 2.4 million tonnes per annum of its initial 10 million tonnes per annum output (4.8 million tonnes per annum post expansion) of sinter quality product, at a 5.5% silica target. The total percentage of sinter product

Oceanic Iron Ore Corp.

Management's Discussion and Analysis of Financial Condition and Results of Operations Third Quarter Report – December 31, 2014 and 2013

could potentially be optimized further if future customers have a higher silica tolerance in their blast furnace operations. As indicated, the Company will decide during the feasibility stage of the project whether a two product circuit is worth pursuing.

Table 7 – Product Results for Sinter Production for the Hopes Advance Project

Element	Base. %	Max. %	Min. %
Fe _{Total}	65.5	67	65
SiO ₂	5.5	6	
MnO	0.16	0.35	
Al ₂ O ₃	0.01	0.02	
C(t)	0.1	0.2	
CaO	0.27	0.3	
Cr ₂ O ₃	0.01	0.02	
Cu	< 0.01	0.01	
Hg	< 0.00003	0.00003	
K ₂ O	< 0.01	0.01	
MgO	0.08	0.15	
Na ₂ O	0.05	0.1	
P ₂ O ₅	0.01	0.02	
S	0.03	0.05	
TiO ₂	< 0.01	0.01	
V ₂ O ₅	< 0.01	0.01	
LOI	0.25	0.5	

Overall, the results of the Product Optimization Study supplement the conclusions reached in the Company's Pre-Feasibility study.

Marketing Study

In April 2013, the Company announced the results of a Value-In-Use Marketing Study completed by Vulcantech Technologies Pty Limited ("Vulcantech"). The Marketing Study was undertaken in order to broaden the Company's strategic understanding of the market for future Hopes Advance iron ore products.

Market analysis was performed summarizing best fit between Hopes Advance iron products and end users taking into consideration geography and technical parameters, in particular focusing on how high quality iron products from the Hopes Advance project might blend with current steel manufacturer feed sources to enhance steel quality and blast furnace results. The Marketing Study also reported on potential premiums and recommendations in respect of optimizing revenues based on end user demand profiles.

The Marketing Study concluded that in addition to the iron unit premium for the high grade Hopes Advance product at 66.6% Fe measured against the 62% Fe benchmark, an estimated minimum 10% value-in-use

Oceanic Iron Ore Corp.

Management's Discussion and Analysis of Financial Condition and Results of Operations Third Quarter Report – December 31, 2014 and 2013

premium can be anticipated due to the product's high quality and low impurities. To illustrate, the Marketing Study concluded that a minimum 10% premium above prevailing prices for Brazilian ores of similar grade could be reasonably expected.

Pot Grate Test Work Program

In August 2013, the Company announced the results of a pot grate test work program (the "Pot Grate Study") performed by Coleraine Minerals Research Laboratory on iron concentrates produced from the Company's Hopes Advance project.

The Pot Grate Study concluded that, with the addition of limestone and dolomite, concentrates from the Company's Hopes Advance project are capable of being transformed into high quality pellets, with very low deleterious elements and compressive strengths of up to 638 lbs and swelling of 10.6%.

This concentrate is expected to be in demand from steelmakers globally who are seeking high quality pellet feed concentrate to enhance production processes.

Shipping Optimization Study

In September 2013, the Company announced the results of its previously announced Shipping Optimization Study (the "Study") led by AMEC Environment and Infrastructure.

This Study concludes with greater certainty that the Company's shipping strategy, which will include direct shipments during ice free months from Breakwater Point and transshipment during winter months, is technically feasible and supports the cost projections contained in the Company's Preliminary Marine Facility and Shipping Logistics Study announced September 22, 2011.

The Study includes the practical perspectives, experience, and inputs provided by shipping and transshipment companies Fednav Limited ("Fednav") Canada Steamship Lines ("CSL"), and Europees Massagoed Overslagbedrijf ("EMO") as well as the port authorities of Rotterdam Netherlands, Nuuk Greenland, and St. Pierre and Miquelon.

The Study identifies three potential transshipment locations that all result in similar average annual shipping costs for the Hopes Advance project. These are Nuuk (Greenland), Rotterdam (Netherlands), and St. Pierre and Miquelon. Each of these presents desirable attributes for transshipment. The actual transshipment location will be determined in consultation with the Company's future strategic partner and will be based on the negotiated commercial terms reached with the applicable port authority and shipping companies at a later date when the project's partner is in place and project financing and construction are imminent. The selected option will be included in the Company's feasibility study.

In the context of current market pricing for Capesize vessels and fuel costs, as well as insurance, port charges, commissions, etc. in addition to the costs associated with dedicated polar class vessels and transshipment, the Study projects estimated average annual shipping costs of approximately \$31 per tonne of product from Nuuk, \$33 per tonne from Rotterdam and \$32 per tonne from St. Pierre and Miquelon with all shipping costs based on a shipment destination to the port of Qingdao, China via the Cape of Good Hope. As a consequence, based on the operating cost conclusions derived from the Company's Prefeasibility Study, in all instances the resulting cash cost CFR China is projected at less than \$65/ tonne.

Oceanic Iron Ore Corp.

Management's Discussion and Analysis of Financial Condition and Results of Operations Third Quarter Report – December 31, 2014 and 2013

At the time the Shipping Optimization Study was published, the price of oil was markedly higher. Therefore using current oil prices would result in a decrease in annual average shipping costs.

In the event that some future product is sold into Europe the average annual shipping costs would decrease.

Eddy Canova, P.Geo., OGQ(403), a Qualified Person as defined by NI 43-101, has reviewed and is responsible for the technical information contained in this document.

Appointment of Chief Executive Officer and Chief Financial Officer

At the senior management level, as the Company advances its negotiations with potential strategic partners, and to more appropriately reflect their roles within the Company, in November, 2014, Alan Gorman accepted the role of CEO, in addition to his role as President. Steven Dean remains Executive Chairman.

Furthermore, in November 2014, Irfan Shariff, the Company's CFO and Corporate Secretary, has resigned to take on another role outside the industry. Mr. Shariff retains an advisory role to ensure continuity of information within the Company. Chris Batalha was appointed CFO and Corporate Secretary, replacing Mr. Shariff. Mr. Batalha joined the Company in 2011 and prior to his appointment as CFO and Corporate Secretary served as the Company's Corporate Controller.

Overall Performance and Results of Operations

Total assets increased to \$43,263,347 at December 31, 2014 from \$42,353,032 at March 31, 2014. The most significant assets at December 31, 2014 were mineral properties of \$40,257,154 (March 31, 2014: \$38,994,208), cash of \$1,984,270 (March 31, 2014: \$2,093,897), and receivables of \$607,561 (March 31, 2014: \$695,994). The Company's net working capital deficit at December 31, 2014 was \$136,445. On October 9, 2014, the Company completed a non-brokered private placement for aggregate proceeds of \$3,049,750. Further details on the private placement are set out below.

The net increase in mineral properties of approximately \$1.3 million reflects the costs incurred in respect of the continued development of the Hopes Advance project, including fieldwork and associated costs to complete legislated minimum work requirements on certain claims, as well as costs to progress the environmental permitting process.

The decrease in cash during the period of \$109,627 resulted from \$1,767,995 incurred from investing activities, \$1,179,582 incurred in operating activities, partially offset by a cash inflow of \$2,837,950 in financing activities. Cash outflows from investing activities included \$1,776,283 incurred on mineral property expenditures as described above, partially offset by interest income received of \$8,288. Financing activities comprised net proceeds from the private placement of \$2,972,950, partially offset by interest paid on the Convertible Debenture of \$135,000.

The decrease in receivables to December 31, 2014 of \$88,433 results from the receipt of input tax credit refunds claimed in prior periods.

Three month period ended December 31, 2014 and 2013

The Company incurred a net loss of \$707,976 during the three months ended December 31, 2014 (2013: \$788,825). The most significant operating expense incurred were non-cash share-based payments of \$195,592 (2013: \$281,907). Non-cash share-based payments represent the Black-Scholes calculated fair

Oceanic Iron Ore Corp.

Management's Discussion and Analysis of Financial Condition and Results of Operations Third Quarter Report – December 31, 2014 and 2013

value of the stock options vested during the period from options granted to directors, officers, employees and consultants during the period, in addition to the vesting of Restricted Share Units ("RSUs") granted to directors and officers in November 2014 and November 2013. Further, in November 2014, the Company re-priced all issued and outstanding stock options from prior periods which resulted in an increase to the fair value of the stock options previously issued, and an increase to non-cash share based payments during the period.

Other significant operating expenses incurred were consulting and management fees of \$114,367 (2013: \$137,500) incurred to support the Company's operations, and wages and benefits of \$100,718 (2013: \$111,890). These expenses experienced a decrease from the same period in the prior year as a result of the Company's decision for management fee and salary reductions with key management of the Company. The reductions will amount to normalized savings of approximately \$63,000 per quarter going forward.

During the three months ended December 31, 2014, the Company recorded interest income of \$5,708 (2013: \$10,176), which consisted of interest earned on the Company's term deposits. The Company incurred \$145,548 of interest and other financing expense during the three months ended December 31, 2014 (2013: \$86,439). The interest and other financing expense comprised non-cash accretion expense of the convertible debenture, which was issued in May 2013.

Nine month period ended December 31, 2014 and 2013

The Company incurred a net loss of \$1,648,728 during the nine months ended December 31, 2014 (2013: \$2,061,747). The most significant operating expenses incurred were consulting and management fees of \$389,367 (2013: \$412,500) incurred to support the Company's operations, and wages and benefits of \$318,452 (2013: \$327,025). These expenses experienced a decrease from the same period in the prior year as a result of the Company's decision for management fee and salary reductions with key management of the Company. The reductions will amount to normalized savings of approximately \$252,000 per year going forward.

Other significant operating expenses incurred were non-cash share-based payments of \$269,660 (2013: \$797,477). Non-cash share-based payments represent the Black-Scholes calculated fair value of the stock options vested during the period from options granted to directors, officers, employees and consultants during the period, in addition to the vesting of Restricted Share Units ("RSUs") granted to directors and officers in November 2014 and November 2013. Further, in November 2014, the Company re-priced all issued and outstanding stock options from prior periods which resulted in an increase to the fair value of the stock options previously issued, and an increase to non-cash share based payments during the period.

During the nine months ended December 31, 2014, the Company recorded interest income of \$14,465 (2013: \$77,234), which consisted of interest earned on the Company's term deposits. The Company incurred \$424,462 of interest and other financing expense during the nine months ended December 31, 2014 (2013: \$261,277). The interest and other financing expense comprised non-cash accretion expense of the convertible debenture, which was issued in May 2013. Finally, the Company recorded a deferred tax recovery during the nine months ended December 31, 2014 of \$246,758 (2013: \$466,399), to recognize the tax benefits of additional non-capital losses in the year.

Oceanic Iron Ore Corp.

Management's Discussion and Analysis of Financial Condition and Results of Operations Third Quarter Report – December 31, 2014 and 2013

Liquidity and Capital Resources

While the financial statements have been prepared on the basis that the Company will continue as a going concern, which contemplates the realization of assets and settlement of liabilities in the normal course of business as they come due, there are certain conditions and events that may cast significant doubt on the validity of this assumption. For the nine months ended December 31, 2014, the Company reported a loss of \$1,648,728 and as at that date had an accumulated deficit of \$24,711,966 and a working capital deficit of \$136,445. Although the Company completed a non-brokered private placement in October, 2014 as discussed below, the Company will need to raise sufficient funds, either through debt or equity financing, in order to finance ongoing development, as well as claim maintenance and administrative expenses over the coming 12 months. The success of raising such funds cannot be assured.

Factors that could affect the availability of financing include the Company's performance, the state of international debt and equity markets, investor perceptions and expectations, the retention of key executive management and the state of global financial and metals markets. As at December 31, 2014, the Company did not have sufficient cash resources to settle outstanding balances. Included in the Company's current outstanding balance is \$2,602,182 relating to the liability component of its convertible debenture which is due and payable in November 2015. As discussed below, the Company has the right to settle any of the outstanding principle balance in common shares.

Capital Restructuring

Effective July 2, 2014, the Company completed a consolidation of its securities on the basis of ten (10) pre-consolidation common shares for one (1) post-Consolidation common share resulting in 19,661,822 common shares issued and outstanding as at the effective date of July 2, 2014. All common share, share option, share purchase warrant, restricted share unit and per share amounts in the unaudited condensed interim financial statements for the nine months ended December 31, 2014 as well as this MD&A have been retrospectively restated to present post-consolidation amounts.

Convertible Debenture

On May 23, 2013, the Company completed a non-brokered financing of \$3 million by way of issuance of a convertible debenture, which bears interest, payable quarterly, at a rate of 6% over a 30 month term.

The principal amount of the debenture is convertible to common shares of the Company at a price of \$1.60 per share at the election of the subscriber. In addition, and subject to receipt of all required regulatory approvals, the Company has the right at any time to pay all or any part of the unpaid principal in respect of the debenture in common shares, where the issue price of each common share will be equal to the volume weighted average trading price for the 20 days prior to the date of notice of the conversion.

In the event that the volume weighted average trading price of common shares is equal to or greater than \$1.60 per share for any 20 consecutive trading day period during the term of the debenture, the principal and interest owing under the debenture will be automatically converted into common shares of the Company.

Issuance costs of \$210,448 were incurred and are being amortized to the statements of comprehensive loss over the life of the convertible debenture. Accretion and other financing expense for the three and nine

Oceanic Iron Ore Corp.

Management's Discussion and Analysis of Financial Condition and Results of Operations Third Quarter Report – December 31, 2014 and 2013

months ended December 31, 2014 was \$145,548 and \$424,462 respectively (2013: \$86,439 and \$218,408, respectively).

Private Placement

On October 9, 2014, the Company completed a non-brokered private placement issuing 15,248,750 units at \$0.20 per unit for aggregate gross proceeds of \$3,049,750. Each unit consisted of one common share of the Company and one common share purchase warrant. Each whole warrant entitles the holder to acquire one common share of the Company at a price of \$0.30 per share until April 9, 2017. The Company incurred cash share issue costs in the amount of \$76,800 in connection with the private placement. The share capital was valued using the closing stock price of the Company on the completion date of the private placement, with the residual amount of \$381,219 allocated to the warrants and recognized in contributed surplus.

Off-Balance Sheet Arrangements

As at December 31, 2014, the Company had no off-balance sheet arrangements.

Summary of Quarterly Results

Below is a summary of results for the eight most recently completed quarters in accordance with IFRS:

	Q3 2015	Q2 2015	Q1 2015	Q4 2014
Revenues (Note 1)	\$ -	\$ -	\$ -	\$ -
Net loss	\$ (707,976)	\$ (467,715)	\$ (473,037)	\$ (344,210)
Basic and diluted loss per share	\$ (0.02)	\$ (0.02)	\$ (0.02)	\$ (0.04)

	Q3 2014	Q2 2014	Q1 2014	Q4 2013
Revenues (Note 1)	\$ -	\$ -	\$ -	\$ -
Net loss	\$ (788,825)	\$ (428,643)	\$ (844,279)	\$ (741,905)
Basic and diluted loss per share	\$ (0.04)	\$ (0.02)	\$ (0.04)	\$ (0.04)

Note 1 – As the Company has yet to achieve commercial production from its mineral related assets, the Company has no Revenue to report during the financial reporting periods noted above.

The decrease in net loss in Q2 2014 versus Q1 2014 and Q4 2013 is attributed to the decrease in Black-Scholes calculated fair value of share-based payments recorded given the majority of the share-based payments from the vesting of 3,055,000 stock options granted in January 2013 were recognized in the two preceding quarters. The increase in net loss in Q3 2014 compared to Q2 2014 is due to an increase in share-based payments representing the Black-Scholes calculated fair value of the stock options vested during the period from options granted to directors, officers, employees and consultants during prior

Oceanic Iron Ore Corp.

Management's Discussion and Analysis of Financial Condition and Results of Operations Third Quarter Report – December 31, 2014 and 2013

periods, the effect on the fair value of all issued and outstanding stock options that were re-priced effective November, 2013, as well as the vesting of Restricted Share Units ("RSUs") granted to directors, officers, and employees in November 2013. The increase in net loss in Q3 2014 is also due to increased corporate development and related legal expenditures incurred during the quarter. The net loss increased to \$473,037 and \$467,715 in Q1 and Q2 2015, respectively when compared to Q4 2014 due to a one time adjusting entry made during Q4 2014 to reflect the correct share-based payment balance for the year ended March 31, 2014. The increase in net loss in Q3 2015 versus Q2 2015 and Q1 2015 is attributed to an increase in share-based payments representing the Black-Scholes calculated fair value of the stock options vested during the period from options granted to directors, officers, employees and consultants during the period. Further, during Q3 2015 there was no deferred income tax recovery recognized during the quarter as a result of the deferred income tax liability being eliminated in Q2 2015.

Critical Accounting Policies

A detailed summary of all the Company's significant accounting policies is included in Note 3 to the audited annual financial statements for the year ended March 31, 2014.

Recently Issued Accounting Standards

a) Recently issued and applied accounting standards

Pronouncements affecting accounting policies only

IFRIC 21, Levies ("IFRIC 21")

The Company adopted IFRIC 21 on April 1, 2014 with retrospective application. IFRIC 21 provides guidance on the accounting for a liability to pay a levy, if that liability is within the scope of IAS 37, Provisions, Contingent Liabilities and Contingent Assets. Levies are imposed by governments in accordance with legislation and do not include income taxes, which are accounted for under IAS 12, Income Taxes or fines or other penalties imposed for breaches of legislation.

The interpretation was issued to address diversity in practice around when the liability to pay a levy is recognized. An example of a common levy is property taxes. IFRIC 21 defines an obligating event as the activity that triggers the payment of the levy, as identified by legislation. A liability to pay a levy is recognized at the date of the obligating event, which may be at a point in time or over a period of time. The fact that an entity is economically compelled to continue to operate in the future, or prepares its financial statements on a going concern basis, does not create an obligation to pay a levy that will arise in a future period as a result of continuing to operate.

The adoption of IFRIC 21 did not affect the Company's financial statements or disclosures as the Company's analysis determined that no changes were required to the existing accounting treatment for levies.

Oceanic Iron Ore Corp.

Management's Discussion and Analysis of Financial Condition and Results of Operations
Third Quarter Report – December 31, 2014 and 2013

b) Accounting standards recently issued but not yet applied

IFRS 9 – Financial instruments

The complete version of IFRS 9 was issued in July 2014. It replaces the guidance in IAS 39 that relates to the classification and measurement of financial instruments. IFRS 9 retains but simplifies the mixed measurement model and establishes three primary measurement categories for financial assets: amortized cost, fair value through OCI and fair value through profit and loss. The basis of classification depends on an entity's business model and the contractual cash flows of the financial asset. Investments in equity instruments are required to be measured at fair value through profit or loss with the irrevocable option at inception to present changes in fair value in OCI not recycling. There is now a new expected credit losses model that replaces the incurred loss impairment model used in IAS 39. For financial liabilities there were no changes to classification and measurement except for the recognition of changes in own credit risk in other comprehensive income, for liabilities designated at fair value through profit or loss. The standard is effective for accounting periods beginning on or after January 1, 2018. The Company has yet to commence assessing the impact of this new standard.

Critical Accounting Estimates

The preparation of the financial statements requires management to make judgments, estimates and assumptions that affect the application of accounting policies and the reported amounts of assets, liabilities, income and expenses. Areas requiring the use of estimates include measurement of advance royalty payables, fair value of the liability component of the convertible debenture (which includes estimates of (i) the amount and timing of cash flows, and (ii) the Company's cost of debt), and measurement and recovery of deferred tax benefits. Actual results may differ from these estimates.

Estimates and underlying assumptions are reviewed on an ongoing basis. Revisions to accounting estimates are recognized in the period in which the estimates are revised and in any future periods affected.

Information about critical judgments in applying accounting policies that have the most significant effect on the amounts recognized in the financial statements is included in the notes to the annual audited financial statements for the year ended March 31, 2014 where applicable.

Financial Instruments and Other Instruments

Financial Risk Management

The Company is exposed in varying degrees to a variety of financial instrument related risks. The board approves and monitors the risk management processes.

Credit Risk

Credit risk arises from the potential for non-performance by counterparties of contractual financial obligations. The Company's exposure to credit risk is on its cash and cash equivalents and receivables. The Company has concentration of risk with respect to cash being held with two large Canadian financial institutions. The Company's credit risk is mitigated by maintaining its financial liquid assets with highly reputable counterparties. The maximum exposure to credit risk is equal to the carrying value of the financial assets noted above.

Oceanic Iron Ore Corp.

Management's Discussion and Analysis of Financial Condition and Results of Operations Third Quarter Report – December 31, 2014 and 2013

Liquidity Risk

Liquidity risk is the risk that the Company cannot meet its obligations as they fall due. The Company's cash and cash equivalents are invested in business accounts and term deposits which are available on demand. The Company manages liquidity risk by preparing and maintaining cash forecasts, which illustrate cash spent to date and the Company's cash needs over the short term. Contractual undiscounted cash flow requirements for financial liabilities as at December 31, 2014 and March 31, 2014 are presented below.

December 31, 2014

	Less than 1 year	1 - 3 years	4 - 5 years	Total
Accounts payable and accrued liabilities	\$ 97,775	\$ -	\$ -	\$ 97,775
Due to related parties	16,457	-	-	16,457
Advance royalty payable	200,000	400,000	-	600,000

March 31, 2014

	Less than 1 year	1 - 3 years	4 - 5 years	Total
Accounts payable and accrued liabilities	\$ 718,977	\$ -	\$ -	\$ 718,977
Due to related parties	14,852	-	-	14,852
Advance royalty payable	200,000	600,000	-	800,000

The Company's ability to continue operations in the normal course of business is dependent on several factors, including the ability to secure additional financing. In addition, the recoverability of the amounts shown for mineral properties are dependent upon the existence of economically recoverable reserves, the ability of the Company to obtain necessary financing to complete the development of those reserves and upon future profitable production, all of which are uncertain.

Market Risk

Market risk is the risk that the fair market value of the Company's financial instruments will significantly fluctuate due to changes in market prices. The value of the financial instruments can be affected by changes in interest rates, foreign exchange rates and equity and commodity prices. The Company is exposed to market risk in its cash and cash equivalents.

The Company's financial instruments are not subject to significant fluctuation due to changes in equity prices of investments included in commodity prices or foreign exchange rates.

The Company also invests surplus cash in fixed rate term deposits. It is the Company's policy to reduce interest rate risk over future cash flows through the use of instruments with a history of returns. A 1% change in interest rates would have a \$20,345 impact on net loss and comprehensive loss.

Fair value

Fair value is based on available public market information or, when such information is not available, estimated using present value techniques and assumptions concerning the amount and timing of future cash flows and discount rates which factor in the appropriate credit risk. The carrying values of cash and cash equivalents, receivables, restricted cash, and the liability component of the convertible debenture approximate their fair values due to their short term nature.

Oceanic Iron Ore Corp.

Management's Discussion and Analysis of Financial Condition and Results of Operations
Third Quarter Report – December 31, 2014 and 2013

Commitments

Effective March 1, 2011 (amended on July 1, 2012); the Company entered into an agreement with an affiliated company, with a director and officer in common, in respect of shared lease, overhead and service costs. Under the agreement, the Company is billed quarterly for office rental and other services relating to its office in Vancouver. The agreement expires on September 29, 2015. Either party may terminate the agreement by providing 90 days' notice.

Effective May 25, 2012, the Company entered into an agreement with Monit International Inc. in respect of the leasing of office space in Montreal, Québec. The agreement expires on January 31, 2023, but the Company may terminate the agreement effective December 31, 2016 with six months' notice.

As part of the acquisition of the Ungava Bay mineral properties, commencing on November 30, 2011, Oceanic must pay advance net smelter royalty ("NSR") payments of \$200,000 per year, which will be credited against all future NSR payments payable from production. The Company made its fourth annual payment on November 25, 2014.

The committed charges for the Company are as follows:

March 31,	Vancouver office rent	Montreal office rent	NSR payments	Total commitments
2015	72,853	65,392	200,000	338,245
2016	-	132,973	200,000	332,973
Thereafter	-	175,761	400,000	575,761
	\$ 72,853	\$ 374,126	\$ 800,000	\$ 1,246,979

Oceanic Iron Ore Corp.

Management's Discussion and Analysis of Financial Condition and Results of Operations Third Quarter Report – December 31, 2014 and 2013

Related Party Transactions and Key Management Compensation

a) Key management compensation

Key management includes the Company's directors, Chief Executive Officer, Chief Financial Officer and President and Chief Operating Officer. Compensation awarded to key management is presented in the table below:

Related Party	Compensation Type	Three months ended December 31, 2014	Three months ended December 31, 2013	Nine months ended December 31, 2014	Nine months ended December 31, 2013
Steven Dean Executive Chairman and Director	Share-based payments	\$ 64,142	135,391 \$	\$ 77,126	294,836
Alan Gorman - President and CEO	Wages, benefits, and share- based payments	186,052 \$	99,849	265,623 \$	412,112
Gordon Keep	Directors' fees and share- based payments	14,431	29,480	18,505	75,369
Hon. John D. Reynolds P.C.	Directors' fees and share- based payments	12,856	16,953	16,930	40,157
Jean Martel*	Directors' fees and share- based payments	14,431	3,729	18,505	10,729
Gregg Sedun	Share-based payments	6,281	19,379	7,855	35,583
Chris Batalha CFO and Corporate Secretary	Wages, benefits, and share- based payments	12,525	-	12,525	-
Irfan Shariff	Share-based payments	9,373	50,050	15,671	118,106
		\$ 320,091 \$	354,831 \$	\$ 432,738 \$	986,892

* Pursuant to the director bios provided in the recent Management Information Circular in respect of the Company's 2014 AGM, the Company clarifies that Mr. Martel's directorship with the Business Development Bank of Canada concluded as of December 2013.

b) Payments for services by related parties

During the three and nine months ended December 31, 2014, the Company incurred corporate consulting fees of \$55,000 (2013: \$82,500) and \$220,000 (2013: 247,500), respectively to Sirocco Advisory Services Ltd., a company controlled by Steven Dean, a director and officer of the Company.

During the three and nine months ended December 31, 2014, the Company incurred corporate consulting fees of \$18,542 (2013: \$40,000) and \$98,542 (2013: \$120,000), respectively, to Shariff Advisory Services Ltd., a company controlled by Irfan Shariff, a former officer of the Company.

As disclosed in the section entitled "Commitments", the Company is charged shared lease and overhead, and service costs by Atlantic Gold Corporation (formerly Spur Ventures Inc.), a company with a director and officer in common, being Steven Dean and Irfan Shariff, respectively. For the three and nine months ended December 31, 2014, the Company incurred \$38,852 (2013: 33,959) and \$111,705 (2013: 102,086), respectively in shared lease, overhead, and service costs. Refer to the section entitled "Commitments" for a listing of future commitments in respect of such lease costs.

Oceanic Iron Ore Corp.

Management's Discussion and Analysis of Financial Condition and Results of Operations Third Quarter Report – December 31, 2014 and 2013

Amounts due to related parties at December 31, 2014 amounted to \$16,457 (March 31, 2014: \$14,852). All related party transactions were made on terms equivalent to those that prevail in arm's length transactions. None of the amounts due to related parties are secured against assets of the Company.

Outstanding Share Data

As at the date of this report, there were 35,048,136 common shares issued and outstanding.

As at the date of this report, there were 3,404,350 stock options, 19,032,500 common share purchase warrants, and 1,481,835 RSUs outstanding.

As discussed in the section entitled "Convertible Debenture", under the terms of the convertible debenture, the principal amount of the debenture can be converted, at the election of the subscriber, to 1,875,000 common shares of the Company at a price of \$1.60 per share. In addition, and subject to receipt of all required regulatory approvals, the Company has the right at any time to pay all or any part of the unpaid principal in respect of the debenture in common shares, where the issue price of each common share will be equal to the volume weighted average trading price for the 20 days prior to the date of notice of the conversion.

In the event that the volume weighted average trading price of common shares is equal to or greater than \$1.60 per share for any 20 consecutive trading day period during the term of the debenture, the principal and interest owing under the debenture will be automatically converted into 1,875,000 common shares of the Company at \$1.60 per common share.

Risks and Uncertainties

The Company is in the business of acquiring, exploring and, if warranted, developing and exploiting natural resource properties. At present, the mineral properties owned by the Company are located in Québec, Canada. Due to the nature of the Company's proposed business and the present stage of exploration of its mineral properties (which are primarily exploration), the following risk factors, among others, will apply:

Going Concern

The financial statements have been prepared on a going concern basis, which assumes that the Company will continue in operation for the foreseeable future and will be able to realize its assets and discharge its liabilities in the normal course of business.

While these financial statements have been prepared on the basis that the Company will continue as a going concern, which contemplates the realization of assets and settlement of liabilities in the normal course of business as they come due, there are certain conditions and events that may cast significant doubt on the validity of this assumption. For the nine months ended December 31, 2014, the Company reported a loss of \$1,648,728 and as at that date had an accumulated deficit of \$24,711,966 and a working capital deficit of \$136,445. Although the Company completed a non-brokered private placement in October, 2014 as discussed in the section entitled "Liquidity and Capital Resources", the Company will need to raise sufficient funds in order to finance ongoing exploration and administrative expenses over the coming 12

Oceanic Iron Ore Corp.

Management's Discussion and Analysis of Financial Condition and Results of Operations Third Quarter Report – December 31, 2014 and 2013

months. The success of raising such funds cannot be assured. Factors that could affect the availability of financing include the Company's performance, the state of international debt and equity markets, investor perceptions and expectations, the retention of key executive management and the state of global financial and metals markets.

These financial statements do not reflect the adjustments to the carrying values of assets and liabilities and the reported expenses and statement of financial position classifications that would be necessary were the going concern assumption deemed to be inappropriate, and these adjustments could be material.

Exploration, Development and Operating Risks

The exploration for and development of mineral deposits involves significant risks which even a combination of careful evaluation, experience and knowledge may not eliminate. Few properties that are explored are ultimately developed into producing mines. Major expenses may be required to locate and establish mineral reserves, to develop metallurgical processes and to construct mining and processing facilities at a particular site. It is impossible to ensure that the exploration or development programs planned by the Company will result in a profitable commercial mining operation. Whether a mineral deposit will be commercially viable depends on a number of factors, some of which are: the particular attributes of the deposit, such as quantity and quality of the minerals and proximity to infrastructure; mineral prices, which are highly cyclical; and government regulations, including regulations relating to prices, taxes, royalties, land tenure, land use, importing and exporting of minerals and environmental protection. The exact effect of these factors cannot be accurately predicted but could have a material adverse effect upon the Company's operations.

Mining operations generally involve a high degree of risk. The operations of the Company are subject to all the hazards and risks normally encountered in the exploration, development and production of minerals, including unusual and unexpected geologic formations, seismic activity, rock bursts, cave-ins, flooding and other conditions involved in the drilling and removal of material, any of which could result in damage to, or destruction of, mines and other producing facilities, damage to life or property, environmental damage and possible legal liability. Although adequate precautions to minimize risk will be taken, milling operations are subject to hazards such as equipment failure or failure of retaining dams around tailings disposal areas, which may result in environmental pollution and consequent liability.

There is no certainty that the expenditures made by the Company toward the search and evaluation of minerals will result in discoveries of mineral resources, Mineral Reserves or any other mineral occurrences.

Political Stability and Government Regulation Risks

The operations of the Company are currently conducted in Québec, Canada. As such, the operations of the Company are exposed to various levels of political, economic and other risks and uncertainties. These risks and uncertainties include, but are not limited to: terrorism; extreme fluctuations in currency exchange rates; and changing political conditions, currency controls and governmental regulations. Changes, if any, in mining or investment policies or shifts in political attitudes in Québec or Canada more broadly may adversely affect the operations or profitability of the Company. Operations may be affected in varying degrees by government regulations with respect to, but not limited to, restrictions on production, price controls, export controls, currency remittance, income taxes, expropriation of property, foreign investment, maintenance of claims, environmental legislation, land use, land claims of local people, water use and mine safety. For example, in 2013 the Government of Québec announced proposed changes to Québec's Mining Act, which were subsequently defeated in the Legislature. It is possible that amended changes may be proposed at some future date. Failure to comply strictly with applicable laws, regulations and local practices relating to mineral rights applications and tenure could result in loss, reduction or expropriation of entitlements, or the imposition of additional local or foreign parties as joint venture partners with carried or other interests.

Oceanic Iron Ore Corp.

Management's Discussion and Analysis of Financial Condition and Results of Operations Third Quarter Report – December 31, 2014 and 2013

The occurrence of these various factors and uncertainties cannot be accurately predicted and could have an adverse effect on the operations or profitability of the Company.

Insurance and Uninsured Risks

The business of the Company is subject to a number of risks and hazards in general, including adverse environmental conditions, industrial accidents, labor disputes, unusual or unexpected geological conditions, ground or slope failures, changes in the regulatory environment and natural phenomena such as inclement weather conditions, floods and earthquakes. Such occurrences could result in damage to mineral properties or facilities and equipment, personal injury or death, environmental damage to properties of the Company or others, delays in mining, monetary losses and possible legal liability.

Although the Company may maintain insurance to protect against certain risks in such amounts as it considers being reasonable, its insurance may not cover all the potential risks associated with a mining company's operations. The Company may also be unable to maintain insurance to cover these risks at economically feasible premiums. Insurance coverage may not be available or may not be adequate to cover any resulting liability. Moreover, insurance against risks such as environmental pollution or other hazards as a result of exploration and production is not generally available to the Company or to other companies in the mining industry on acceptable terms. The Company might also become subject to liability for pollution or other hazards which it may not be insured against or which the Company may elect not to insure against because of premium costs or other reasons. Losses from these events may cause the Company to incur significant costs that could have a material adverse effect upon its financial performance and results of operations.

Environmental Risks and Hazards

All phases of the Company's operations are subject to environmental regulation in the various jurisdictions in which it operates. These regulations mandate, among other things, the maintenance of air and water quality standards and land reclamation. They also set forth limitations on the generation, transportation, storage and disposal of solid and hazardous waste. Environmental legislation is evolving in a manner that will require stricter standards and enforcement and involve increased fines and penalties for non-compliance, more stringent environmental assessments of proposed projects, and a heightened degree of responsibility for companies and their officers, directors and employees. There is no assurance that future changes in environmental regulation, if any, will not adversely affect the Company's operations. Environmental hazards may exist on properties in which the Company holds interests which are unknown to the Company at present and which have been caused by previous or existing owners or operators of the properties.

Failure to comply with applicable laws, regulations and permitting requirements may result in enforcement actions there under, including orders issued by regulatory or judicial authorities causing operations to cease or be curtailed, and may include corrective measures requiring capital expenditures, installation of additional equipment or remedial actions. Parties engaged in mining operations or in the exploration or development of mineral properties may be required to compensate those suffering loss or damage by reason of the mining activities and may have civil or criminal fines or penalties imposed for violations of applicable laws or regulations.

Amendments to current laws, regulations and permits governing operations and activities of mining and exploration companies, or more stringent implementation thereof, could have a material adverse impact on the Company and cause increases in exploration expenses, capital expenditures or require abandonment or delays in development of new mining properties.

Oceanic Iron Ore Corp.

Management's Discussion and Analysis of Financial Condition and Results of Operations Third Quarter Report – December 31, 2014 and 2013

Fluctuations in Metal Prices

The price of the common shares, and the financial results and exploration, development and mining activities of the Company, may in the future be significantly and adversely affected by declines in the prices of iron ore and other metals or minerals. The prices of iron ore and other metals or minerals fluctuate widely and are affected by numerous factors beyond the control of the Company such as the sale or purchase of commodities by various central banks and financial institutions, interest rates, exchange rates, inflation or deflation, fluctuations in the value of the United States dollar and other foreign currencies, global and regional supply and demand, the political and economic conditions and production costs of major mineral-producing countries throughout the world, the cost of substitutes, inventory levels and carrying charges. Future serious price declines in the market prices of iron ore or other metals or minerals could cause continued development of and commercial production from the properties in which the Company holds an interest to be impracticable. Depending on the prices of iron ore and other metals and minerals, cash flow from mining operations could not be sufficient and the Company may lose its interest in, or may be forced to sell, some of its properties. Future production from the Company's properties is dependent upon the prices of iron ore and other metals and minerals being adequate to make these properties economically viable.

In addition to adversely affecting the resource estimates of the Company and its financial condition, declining commodity prices can affect operations by requiring a reassessment of the feasibility of a particular project. Such a reassessment may be the result of a management decision or be required under financing arrangements related to a particular project. Even if a project is ultimately determined to be economically viable, the need to conduct such a reassessment may cause substantial delays or interrupt operations until the reassessment can be completed.

Key Personnel

The Company is dependent upon the services of key executives, including the directors of the Company and a small number of highly skilled and experienced executives and personnel. Due to the relatively small size of the Company, the loss of these persons or the inability of the Company to attract and retain additional highly-skilled employees may adversely affect its business and future operations.

Share Price Volatility and Liquidity

Publicly quoted securities are subject to a relatively high degree of price volatility. It may be anticipated that the quoted market for our shares will be subject to market trends generally, notwithstanding any potential success of us in creating sales and revenues. In addition, our shareholders may be unable to sell significant quantities of shares into the public trading markets without a significant reduction in the price of their shares, if at all.

Disclosure Controls and Procedures

Disclosure controls and procedures ("DC&P") are intended to provide reasonable assurance that information required to be disclosed is recorded, processed, summarized and reported within the time periods specified by securities regulations and that information required to be disclosed is accumulated and communicated to management. Internal controls over financial reporting ("ICFR") are intended to provide reasonable assurance regarding the reliability of financial reporting and the preparation of financial statements for external purpose in accordance with Canadian generally accepted accounting principles.

TSX-V listed companies are not required to provide representations in the annual filings relating to the establishment and maintenance of DC&P and ICFR, as defined in Multinational Instrument 52-109. In particular, the CEO and CFO certifying officers do not make any representations relating to the establishment and maintenance of (a) controls and other procedures designed to provide reasonable assurance that information required to be disclosed by the issuer in its annual filings, interim filings or other

Oceanic Iron Ore Corp.

Management's Discussion and Analysis of Financial Condition and Results of Operations Third Quarter Report – December 31, 2014 and 2013

reports filed or submitted under securities legislation is recorded, processed, summarized and reported within the time periods specified in securities legislation, and (b) a process to provide reasonable assurance regarding the reliability of financial reporting and the preparation of financial statements for external purposes in accordance with the issuer's GAAP.

The issuer's certifying officers are responsible for ensuring that processes are in place to provide them with sufficient knowledge to support the representations they are making in their certificates regarding the absence of misrepresentations and fair disclosure of financial information. Investors should be aware that inherent limitations on the ability of certifying officers of a TSX-V issuer to design and implement on a cost effective basis DC&P and ICFR as defined in Multinational Instrument 52-109 may result in additional risks to the quality, reliability, transparency and timeliness of interim and annual filings and other reports provided under securities legislation.

Forward Looking Statements

This document includes certain "Forward-Looking Statements" as that term is used in applicable securities law. All statements included herein, other than statements of historical fact, including, without limitation, statements regarding potential mineralization and resources, exploration results, and future plans and objectives of the Company, are forward-looking statements that involve various risks and uncertainties. In certain cases, forward-looking statements can be identified by the use of words such as "plans", "expects" or "does not expect", "scheduled", "believes", or variations of such words and phrases or statements that certain actions, events or results "potentially", "may", "could", "would", "might" or "will" be taken, occur or be achieved. There can be no assurance that such statements will prove to be accurate, and actual results could differ materially from those expressed or implied by such statements. Forward-looking statements are based on certain assumptions that management believes are reasonable at the time they are made. In making the forward-looking statements in this presentation, the Company has applied several material assumptions, including, but not limited to, the assumption that: (1) there being no significant disruptions affecting operations, whether due to labour/supply disruptions, damage to equipment or otherwise; (2) permitting, development, expansion and power supply proceeding on a basis consistent with the Company's current expectations; (3) certain price assumptions for iron ore; (4) prices for availability of natural gas, fuel oil, electricity, parts and equipment and other key supplies remaining consistent with current levels; (5) the accuracy of current mineral resource estimates on the Company's property; (6) labour and material costs increasing on a basis consistent with the Company's current expectations; and (7) the ability to achieve the required financing from equity markets, debt markets and/or a strategic partner/off-taker to facilitate the development and eventual construction of the Company's projects. Important factors that could cause actual results to differ materially from the Company's expectations are disclosed under the heading "Risks and Uncertainties" in this MD&A. Such factors include, among others, risks related to the ability of the Company to obtain necessary financing and adequate insurance; the economy generally; fluctuations in the currency markets; fluctuations in the spot and forward price of iron ore or certain other commodities (e.g., diesel fuel and electricity); changes in interest rates; disruption to the credit markets and delays in obtaining financing; the possibility of cost overruns or unanticipated expenses; employee relations. Accordingly, readers are advised not to place undue reliance on Forward-Looking Statements. Except as required under applicable securities legislation, the Company undertakes no obligation to publicly update or revise Forward-Looking Statements, whether as a result of new information, future events or otherwise.

Additional information relating to the Company is available on SEDAR at www.sedar.com.